

PENGUIN

0180

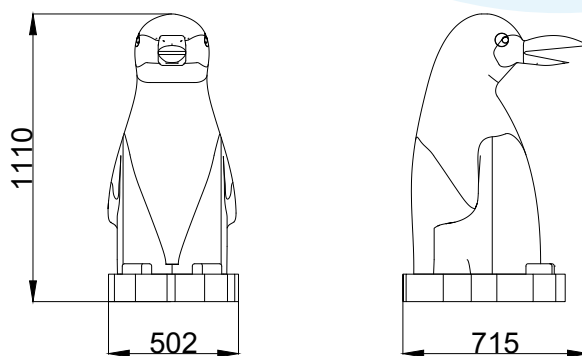

DESCRIPTION:

Penguin water attraction has been designed as an aquatic item for the youngest lovers of water play. The possibility of choosing a color version allows this water attraction to be perfectly integrated into the interiors of every facility. Our water attractions automatically spray water and are also available in a variant with a hand pump, where children can spray water themselves. Penguin offers endless water play pleasure for the youngest pool guests. Thanks to installed hand pump (additional option), this water toy encourages interactive play also with parents. It is a great addition to the equipment of children's paddling pools, whilst meeting all safety rules.

TECHNICAL DATA / mm:

Height:	1110
Width:	502
Length:	715